



## What is the LIMO Set?

### Choice of modern LED luminaires



Omega LED r2m



Omega Pro r2m

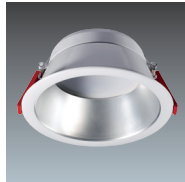

Chalice r2m



Chalice Pro r2m



### r2m Refurbishment Kit



ready2mains™ Gateway

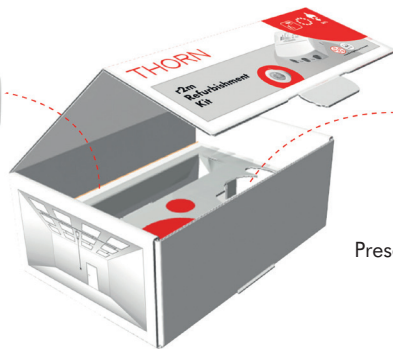

Presence/Daylight Sensor

- The Light Modernisation Set based on the ready2mains™ technology from Tridonic is ideal for a quick and easy 1:1 replacement of luminaires with conventional technology
- Instant solution for energy saving
- Presence detection and daylight control (optional with push-button for manual control)
- No dedicated dimming cables to the luminaires necessary, existing cables can be reused

## How does the ready2mains™ technology work?

### Before

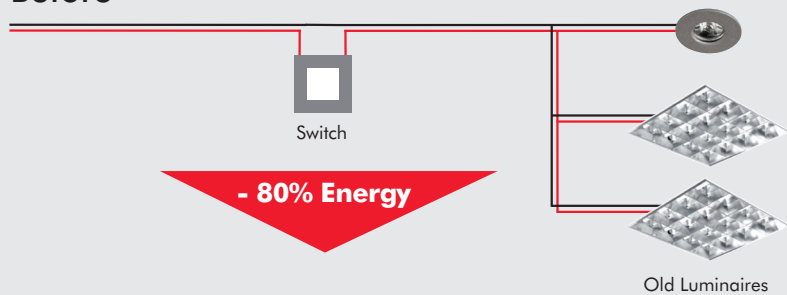

### After

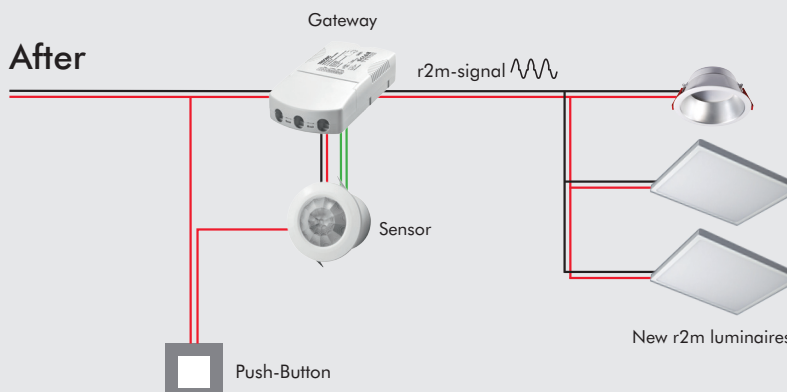

- ready2mains™ uses simple phase-cuts to send digital commands via the mains wiring
- Dimming capabilities without any control cables to luminaires
- Cost-effective installation in next to no time
- Up to 15 r2m luminaires (or max. 400 VA) are controlled as a group, broadcast control for all connected luminaires in that group
- Very stable technology, which uses the existing mains
- No powerline problems, gateway protects supply lines from system incidents



Better lighting quality



Quick 1:1 replacement



Easy installation



Cost effective



Smart controls without costly rewiring



## r2m Refurbishment Kit

With the r2m Refurbishment Kit you can upgrade to highly efficient LED lighting with integrated lighting controls in small and medium sized offices without costly and time consuming rewiring.

Gateway connected load:	0–400 VA
Gateway max. cable lengths derivative at 1.5 mm <sup>2</sup> :	250 m
Presence sensor max. mounting height:	4 m
Presence detection range (PIR):	6 m at 3 m Height
Daylight control default:	519 lx
Article number:	96627986
	R2M REFURBISHMENT KIT

## Which luminaires can be used in the LIMO Set?



### Omega LED r2m

Versatile LED Panel with flexible mounting options.

- For numerous general lighting applications, UGR<22, IP44
- Direct replacement of 4 x 18 W T26 (T8) louvered luminaires
- Installation as recessed luminaires in modular ceilings
- Recessed, surface or suspended mounting with accessories
- Lifetime of 50 000 hours L90

Total luminous flux:	3250 lm
Luminaire efficacy:	95 lm/W
Article number:	96627820
	OMEGA LED 3250 R2M Q622 L840



### Omega Pro r2m

Comfort and style: Ultra slim LED flat panel luminaire with unique glare control

- With UGR<19 and L<2500 cd/m<sup>2</sup> at 65° (complying with EN 12464-1) for high comfort on display screen equipment
- Direct replacement of 4 x 14 W T16 (T5) louvered luminaires
- Installation as recessed luminaires in modular ceilings
- Recessed, surface or suspended mounting with accessories
- Lifetime of 50 000 hours L90

Total luminous flux:	4100 lm
Luminaire efficacy:	100 lm/W
Article number:	96627826
	OMEGA PRO 4100 R2M Q622 L840



### Chalice r2m

Powerful LED Downlight offering an efficient, direct replacement for CFL solutions

- High luminaire efficacy of 100 lm/W
- Efficient replacement of 1 x 18 W up to 2 x 26 W CFL Downlights
- Cut out diameter of 200 mm
- Lifetime of 50 000 hours L80

Total luminous flux:	1300 lm / 2000 lm
Luminaire efficacy:	95–100 lm/W
Article number:	96627916
	CHAL 200 LED1300-840 R2M RSB
	96627918
	CHAL 200 LED2000-840 R2M RSB



### Chalice Pro r2m

High performance LED downlight offering glare control and high LED lifetime

- Class leading efficacy of >110 lm/W
- Ideal with limited space in the ceiling: overall height <100 mm
- Glare free with UGR<19 for demanding lighting requirements
- Compact 150 mm cut out diameter
- Lifetime 50 000 hours L90

Total luminous flux:	1100 lm / 2000 lm
Luminaire efficacy:	110 lm/W
Article number:	96643251
	CHAL PRO LED1100-840 R2M RMB W6
	96643253
	CHAL PRO LED2000-840 R2M RMB W6