

Contrast

96633460 CONT3 52L70-RGBW NB RDMX SP ANT

ISO 9223 C5	IP66	IK08					T _a -20 +25
----------------	------	------	--	--	--	--	---------------------------

Contrast

A large architectural Bracket mounted LED Floodlight with 52 LEDs driven at 700mA and a narrow beam distribution. LED driver, DMX controllable control gear. Class II electrical, IP66, IK08. Body: die-cast aluminium (EN AC-44300), powder coated, textured anthracite (close to RAL7043). Compatible with coastal environments. Glass: tempered, 5mm thick. Gasket: EPDM. Screws: geomet. Equipped with 10kV / 10kA surge protection device. Complete with RGBW LEDs (White = 830)

Dimensions: Ø397 x 206 mm
 Luminaire input power: 113 W
 Luminaire luminous flux: 7211 lm
 Luminaire efficacy: 64 lm/W
 Weight: 12.6 kg



TLG_CON3_F_M_52L.jpg

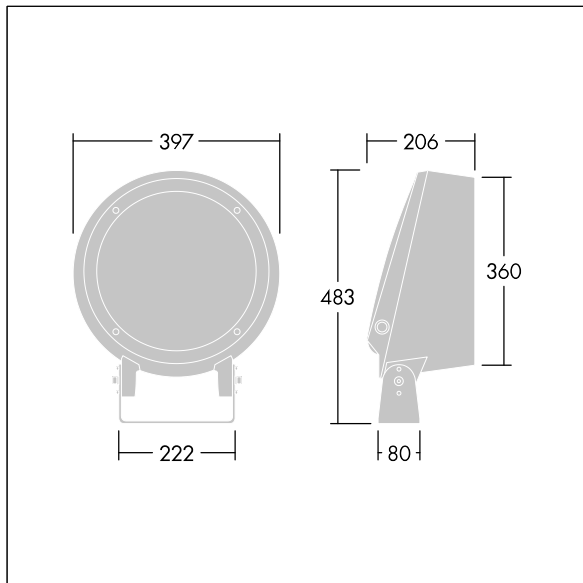

TLG_CONL_M_36-52L.wmf

This product contains a light source of energy efficiency class D.

All values marked with an * are rated values. Thorn uses tried and tested components from leading suppliers, however there may be isolated instances of technology-related failures of individual LEDs during the rated product lifetime. International standards set the tolerance in initial flux and connected load at ±10%. Unless stated otherwise, the values apply to an ambient temperature of 25°C.